

JINGDIAO



MANUFACTURER OF HIGH-SPEED PRECISION MACHINING CENTERS

Price to Performance Advantage

Website: <https://us.jingdiao.com/>



About Us

Established in 1994, Jingdiao is a privately held manufacturer of high precision, high speed 3 & 5 axis machining centers and automation systems. Jingdiao produces over 6,000-8,000 machines per year, has over 5,000 employees, 1,200 engineers and 900 engineers dedicated to research and development. We partner with our customers in solving and providing them the best high speed machining solutions for their manufacturing needs.



U.S. Headquarters

1400 E. Business Center Drive, Ste. 103,
Mount Prospect, IL 60056



Support - Parts - Spindles



5 Axis High Speed High Precision Machining Centers GRA Series

Part accuracy from 2 - 5µm :



GRA50

X/Y/Z Travel	9.3/8.3/6.9 in.
A/C Rotation Range	-15°~125°/360°
Spindle Speed	36,000 rpm 32,000 rpm
Worktable Size	φ4.3 in.
Max. Load	22.0 lb.



GRA100

X/Y/Z Travel	15.7/ 7.9/ 7.9 in.
B/C Rotation Range	±120°/ 360°
Spindle Speed	32,000 rpm 24,000 rpm
Worktable Size	φ6.3 in.
Max. Load	33.1 lb.



GRA200

X/Y/Z Travel	19.7/ 11.0/ 11.8 in.
B/C Rotation Range	-120°~90°/ 360°
Spindle Speed	32,000 rpm 24,000 rpm 20,000 rpm
Worktable Size	φ10.2 in.
Max. Load	110.2 lb.



GRA300

X/Y/Z Travel	15.4/20.1/11.8 in.
B/C Rotation Range	-110°~90°/ 360°
Spindle Speed	32,000 rpm 24,000 rpm 20,000 rpm
Worktable Size	φ11.8 in.
Max. Load	220.5 lb.



GRA400

X/Y/Z Travel	17.7/ 26.8/ 15.7 in.
B/C Rotation Range	-120°~90°/ 360°
Spindle Speed	24,000 rpm 20,000 rpm
Worktable Size	φ15.7 in.
Max. Load	330.7 lb.



GRA500

X/Y/Z Travel	21.7/28.3/17.7 in.
A/C Rotation Range	-115°~90°/ 360°
Spindle Speed	20,000 rpm 15,000 rpm
Worktable Size	φ19.7 in.
Max. Load	661.4 lb.



MRA600

X/Y/Z Travel	25.6/ 26.0/ 19.7 in.
B/C Rotation Range	-120°~90°/ 360°
Spindle Speed	20,000 rpm 15,000 rpm
Table Size	φ24.8 in.
Workload	881.8 lb.

3 Axis High Speed High Precision Machining Centers HGA Series

For precision machining :



HGA400

X/Y/Z Travel	15.7/ 15.7/ 7.9 in.
Spindle Speed	36,000 rpm 32,000 rpm
Worktable Size	20.9 x 16.9 in.
Max. Load	661.4 lb.



HGA600

X/Y/Z Travel	23.6/ 19.7/ 7.9 in.
Spindle Speed	36,000 rpm 32,000 rpm
Worktable Size	25.6 x 25.6 in.
Max. Load	661.4 lb.



HGA800

X/Y/Z Travel	31.5/ 31.5/ 13.8 in.
Spindle Speed	24,000 rpm 20,000 rpm
Worktable Size	33.5 x 33.5 in.
Max. Load	2204.6 lb.

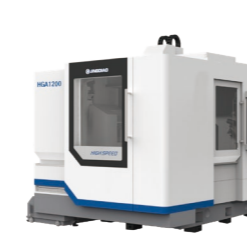

HGA1200

X/Y/Z Travel	47.2/ 31.5/ 13.8 in.
Spindle Speed	24,000 rpm 20,000 rpm
Worktable Size	49.2 x 33.5 in.
Max. Load	2204.6 lb.



HGA2000

X/Y/Z Travel	78.7/31.5/13.8 in.
Spindle Speed	24,000 rpm 20,000 rpm
Worktable Size	80.7x33.5 in.
Max. Load	4409.2 lb.

Graphite Machining Centers

Our dust-proof design combined with positive air pressure can effectively isolate graphite dust and protect the machine components from being damaged.

5 Axis Graphite Mill :



GRA200-GRAPHITE

X/Y/Z Travel	19.7/11.0/11.8 in.
B/C Rotation Range	-120°~90°/360°
Spindle Speed	32,000 rpm
Worktable Size	φ10.2 in.
Max. Load	110.2 lb.

3 Axis Graphite Mill :



PGA600

X/Y/Z Travel	23.6/19.7/7.9 in.
Spindle Speed	32,000 rpm
Worktable Size	25.6x20.5 in.
Max. Load	661.4 lb.

Milling - Grinding 5 Axis Machining Centers

For grinding both brittle and hard parts from to 2 - 5µm :

5 Axis Machining Centers for Production Purposes

Part accuracy from to 10 - 20µm :



GRP150

X/Y/Z Travel	19.7/ 7.9/ 10.2 in.
B/C Rotation Range	-120°~90°/360°
Spindle Speed	24,000 rpm
Worktable Size	φ7.9 in.
Max. Load	44.1 lb.



GRP400

X/Y/Z Travel	17.7/27.6/19.1 in.
A/C Rotation Range	-120°~90°/360°
Spindle Speed	15,000 rpm
Worktable Size	φ15.7 in.
Max. Load	330.7 lb.



MRP2000

X/Y/Z Travel	11.8/15.7/12.2 in.
A/C Rotation Range	-90°~120°/360°
Spindle Speed	20,000 rpm
Worktable Size	φ7.9 in.
Max. Load	66.1 lb.



MRP600

X/Y/Z Travel	25.6/26.0/19.7 in.
A/C Rotation Range	-120°~90°/360°
Spindle Speed	15,000 rpm
Worktable Size	φ24.8 in.
Max. Load	881.8 lb.



MGA200

X/Y/Z Travel	19.7/11.0/11.8 in.
B/C Rotation Range	-120°~90°/360°
Spindle Speed	24,000 rpm
Worktable Size	φ10.2 in.
Max. Load	110.2 lb.

JINGDIAO Automation

Pallet Systems



Machine	MHS25	MHS30	MHS40C	MHS80C	MHS150S
Name	MHS25	MHS30	MHS40C	MHS80C	MHS150S
Pallets	84	24	35	21	16
Max.WP Size	5.1"x4.7"x4.7"	4.7"x4.7"x7.9"	φ3.1"x7.9"	φ11.8"x7.9"	15.7"x15.7"x9.8"
Max. Weight	55 lb.	66 lb.	88 lb.	176 lb.	331 lb.
Adaptive Machine Tools	GRA100 GRA200 GRP150 HGA400 HGA600	GRA200 GRP150 HGA400 HGA600	GRA300 HGA400 HGA600	GRA300 HGA600	GRA400 GRA500 HGA800

Carousel Type

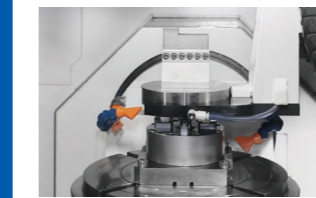

Rack Type for Graphite or Copper Electrodes

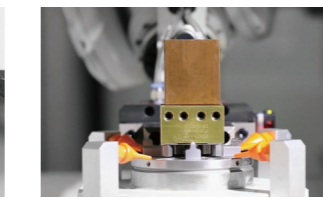
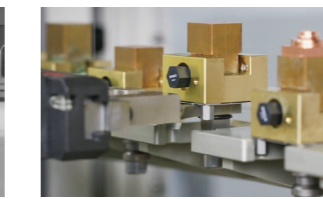
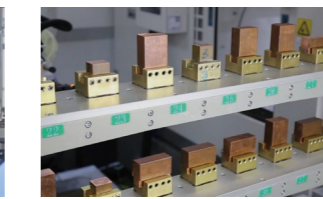

JINGDIAO Made Spindles & Gantry Style "Anti Vibration" Machine Design

- + Jingdiao made spindles;
- + 20,000 rpm / 24,000 rpm / 32,000 rpm / 36,000 rpm;
- + Built in motor cartridge style spindles;
- + Greased packed ceramic bearings;

- + Bed uses grey cast iron because it has good dampening capabilities;
- + Direct drive - simultaneous - RTCP - C axis;
- + Bridge uses 3 guideways for rigid support;
- + Columns use nodular cast iron = 2X as strong as grey cast iron;
- + Casting aging process speeds up taking stress out of the casting castings have rib reinforcement in both the horizontal, vertical & diagonal directions;
- + Jingdiao's high-quality control standards combined with their double-layer insulation system, prevents the outside temp. from affecting the workshop environment which results in consistent & precise machines.



Thermally Stability

Since Jingdiao machines stable there is no need to thermally compensate them. Sensors are located on the spindle, A,C axis, control, chiller, filtration and will notify the operator of abnormal temperature changes.

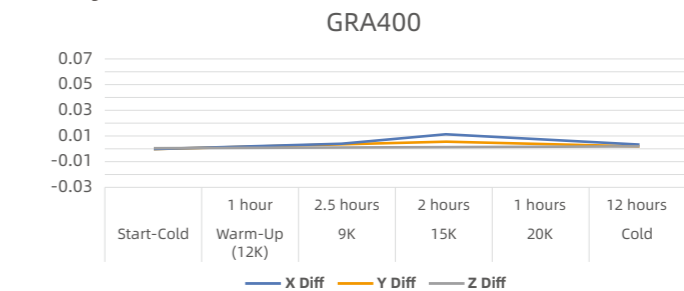

High Quality Tested Subcomponents



JD50 CNC System

The JD50 CNC system developed by JINGDIAO is the brains of the machine. It has the basic functions seen other control systems, but also includes several advanced 5-axis modules developed by JINGDIAO's R&D department. This is how JINGDIAO 5-axis machine tools achieve high machining accuracy, and mirror finishes. Our machining modules are flexible and can be customized based on a customer's machining application.

Basic Characteristics

- + The programming resolution and control resolution are 0.1 µm (3.9x10⁻⁶ in).
- + Supports linear, plane arc, space arc, spiral line, spline and involute interpolation methods.
- + Support pitch compensation and reverse clearance compensation.
- + Support RTCP multi-axis motion control.



System Advantages

- + Various programming methods and flexible technical process design.
- + Abundant types of interfaces and buses, with strong peripheral expansion capabilities.
- + Unique external extended function instructions (G100), which can realize instruction-level peripheral control, human-computer interaction, and complex data operations.



JINGDIAO's own JD50 is easy to learn and its NC codes are similar to a FANUC control.

- | | |
|---|---|
| G00 - Rapid travel. ... | G20 and G21 - Measurement Systems. ... |
| G01 - Linear Interpolation. ... | G90 and G91 - Absolute or Incremental. ... |
| G02 and G03 - Circular Interpolation. ... | G40, G41 and G42 - Cutter Compensation. ... |
| G04 - Dwell. ... | CNC G Codes List. |

JDSoft SurfMill



JINGDIAO's SurfMill CAM software, which has been integrated to overcome the skills gap in places such as the toolroom. In addition to providing a given set of directions for the machine, the company's own integrated CAM system offers several features to aid the operator in navigating the JINGDIAO machining centers.

Prior to producing the NC code, for example, SurfMill will verify the program assuring that there will be no collisions during machining operation. To reduce machine downtime, an Auto-Alignment feature aligns the workpiece in the X, Y and Z axes. SurfMill is also able to compensate for tool length – measuring the length, in addition to the radius – and an On Machine Measurement feature uses a Renishaw probe to determine the critical dimensions of the workpiece and whether it's within tolerance, providing a 3D image of the cut prior to removal.

Standard on HGA- GRA Series

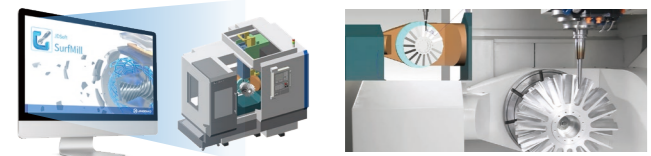

JINGDIAO Digital Twin (DT) Technology

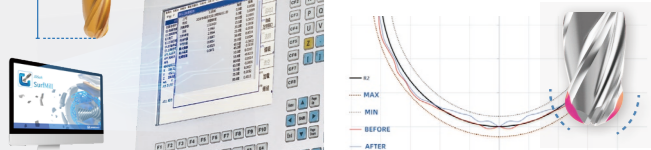

3D tool Length compensation

Tool Wear Measurement

SurfMill is standard with all JINGDIAO machining centers. Training is included and there is no yearly maintenance charge. It can also be used with existing CAM system so you can enjoy the benefits of both systems. If a JINGDIAO post is not available for CAM system, we will provide the information to get one written.



GRA Machining Samples

Turbo Impeller

GRA200
AL7075
Ø2.0"x1.0"

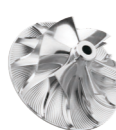

mirror lamp

S136(HRC52)
4.1x4.1x2.5 in.



ear buds Mold

GRA200
3.0x3.0x1.2 in.



Medical Samples

6" Bone Plate

GRA300 \ TC4
26 tools
1:45



Cervical Plates

GRA200
Al 6061
1.0"x.63"x.12"
20RMS
10 mins each



Knee Implant

GRA300
6a14v TI
32RMS
4:21

HGA Machining Samples

Fuel Cell Bipolar Plate Mold Testpiece

HGA600 SKD11(60HRC) 15.7x6.3x1.6 in.



Micro Hole

HGA400 Al 6061
.08"x.08"x.047"
1,158 .002"Ø holes

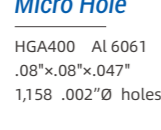

Optical Lamp

HGA600 S136 (HRC52)
Ø3.3"x2.0" Ra<0.07µm (3RMS)



MRA Machining Samples

7-Level Impeller

MRA600
AL 7075-T6
Ø13.78"x11.26"
Roughing-finishing of 249 blades: 16 hrs
One set-up
Unbalance <.6gmm



Flywheel Housing Die Casting

MRA600
ADC12(HB90) 12% Silicon
22.76"x22.05"x7.01"

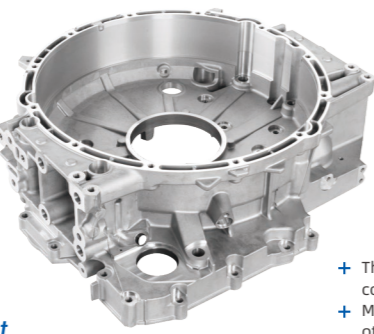

- + The workpiece can be clamped at one time to complete multi-position processing;
- + Milling, boring, drilling, tap-ping, reaming and other pro-cessing methods are used.

Graphite Machining Samples

Thin Wall Electrode

PGA600
Graphite (SGL R8650)
2.76"x0.98"x1.97"
Thin wall feature
High quality surface consistency
Accuracy: ±.01mm (.0004")

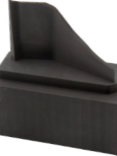

Bottle Neck Electrode

GRA200 GRAPHITE
Poco EDM-2
Machine time: 40 mins
1.31"x1.31"x0.83"
Accuracy: ±.010mm (.0004")



Graphite Electrode

GRA200 GRAPHITE
Poco EDM-2
.49"x.75"x2.16"
Accuracy: ±.015mm (.0006")



Modern Machine Shop

When Automating a Task Beats Automating the Process

A medical manufacturer proves why a high mix of complex work need not deter any manufacturer from automation, whether via robot or pallet system.



MATT DANFORD
Senior Editor, Modern Machine Shop

Machining components for surgical tools is complex work, but Metal Craft prefers a simpler approach to automation. "We just want it to load the machines, so our people can go and do something else," says Jeff Thrun, general manager. Limiting the use of robots to machine tending contrasts starkly with the recommendations of many outside integrators, Thrun says. "They'll say, 'Just tell us what you want done, and we'll turnkey it in our facility and deliver it to you.' I'll say, 'Great, you can put it there on Monday, and I'll call you back on Wednesday, because that job will be done.'" In other words, loading and unloading parts is low-hanging fruit for Metal Craft's collaborative robots. More ambitious work – say, deburring or inspection – might be possible to automate in some cases, but part quantities are often too low and process variability too high for it to be practical. A more limited approach results in a process that still requires attention, but not at the cost of an idle machine tool spindle. "A person has to go over and do the quality inspections, do the SPC [statistical process control] charting, change the tools when they meet their too life expectancy, and that kind of thing – that doesn't change," Thrun explains. "But now, they can run two or three machines instead of one."



METAL CRAFT

BUILT RIGHT. EVERY TIME.
Jonathan - Programmer
Jon - Machinist
Jeff - GM - Operations Manager

This focus has made automation easier to implement, but the team also has made extensive efforts to ensure seamless changeovers from job to job. One result of this work is a modified part-staging system that flexes as-needed to accommodate different-sized workpieces. Another, more recent example of how repeatable setups help make the most of automation involves not a robot, but a pallet changer. In this case, job changeovers are a matter of simply "picking one pallet up off the (conveyor) chain and putting another one on," Thrun says. Experience with both robots and pallets has enabled the shop to evaluate the relative merits of both systems for its applications. Those merits aside, the broader lesson of Metal Craft's journey is that a varied mix of complex work need not deter any manufacturer from automating, whether with robots, pallets or both. As Thrun puts it, "these are just two different ways of delivering parts to the machine." Success depends

on how they are used – and, increasingly for this Minneapolis medical manufacturer, the equipment to which the automation is attached.

Unattended Only, Please

A tour of the 83,000-square-foot shop floor quickly reveals one of this 150-employee company's most striking characteristics: For most of its history, machining has depended as much on the machinists as the machine tools. Thrun cites expertise with setups and workholding as critical to weaning the maximum capability from milling and turning machines. The difference today is that a phrase like "milling and turning" is likely to describe the same machine. Barfed turn-mills have become more common, as have five-axis machining centers, because consolidating setups improves both the quality and the speed of machining. Both goals are critical because customer requirements are changing, Thrun says. That goes not for just the work itself, but also demands surrounding it, such as increased inspection requirements. Meanwhile, machinists remain as hard to find as ever. "In order to grow, we need our people to accomplish more without working any harder. We plan to do that through unattended machining."

So far, he most significant investment toward meeting that goal is a pallet-fed five-axis machining center with capability that sets it apart from the rest of the shop. Capable of machining to accuracy of less than 2 microns and achieving nanometer-level surface finishes, the GRA200 from Jingdiao North America is also an unusual make and model for a U.S. machine shop generally. However, the builder is working to change that, and more broadly, to emphasize the role of high precision in ensuring reliable lights-out machining. In fact, Metal Craft's opportunity to purchase the machine came with one condition: It would be displayed at IMTS 2020 first.

When that event was cancelled, Metal Craft took delivery early. The machinists tasked with running the new machine made the most of the extra time, even opting to master the builder's own CAM system rather than choose a more common option. Nonetheless, the machine "hit every bullet item flawlessly" in a six-month trial. Notably, mastering the machine involved more than just the machine itself. They also had to master the pallet system that came with it. In the process, they essentially would be getting an opportunity to test another form of automation against the shop's first collaborative robot, where the team had already made significant strides in tending a less-precise machine.

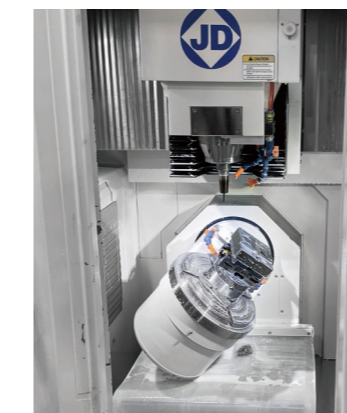

Making Setups Repeatable

Thrun credits multiple team members for the success of that first robot, a UR-10 from Universal Robots. He also credits the integrator who sold it, PCC Robotics, for appreciating the challenges associated with an environment where a "high-volume" order amounts to only 100 parts at most. However, he says the effort really began with the hiring of a young automation engineer who started with Metal Craft as a college intern. In early attempts to maximize unattended machining time, he set the same goal for the robot that the machinists would set later with the pallet system: ensuring time spent setting up did not exceed the time spent cutting parts.

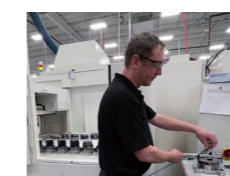

Stretching Skills Further

Although the pallet system has more than paid for itself, Thrun says Metal Craft's future is likely with additional collaborative robots, even as it plans to expand its capacity for fine-tolerance machining.

With one workpiece per station, he explains, the pallet-fed machine can cycle through 24 workpieces before someone has to attend to it. However, only half are likely to be finished parts, because even a five-axis machine requires a second setup for sixth-side operations. Barring an investment in a larger pallet changer (and more pallets to set up beforehand), a robot could conceivably cycle through more parts without intervention, simply because more parts can be staged in front of it. Running only one unique part number at any given time also makes robots a better choice for avoiding line clearance issues – that is, avoiding mixing between jobs, which can be a hazard for quality control.

Regardless, focusing too much on the merits of either system risks missing the point. "All things equal" comparisons of the two delivery mechanisms are easy for Metal Craft because they are seen as just that: delivery mechanisms. Which part runs where depends not on the robot or pallet system, but on the machine itself. Suffice it to say, Metal Craft plans to install another five-axis Jingdiao, although this machine might be fed by a collaborative robot rather than a pallet system.

As for the pallets, the basic idea is also to standardize on workholding and pre-stage setups as much as possible beforehand. To that end, the shop has invested heavily in pallets, 5C collets and two types of vise (a model from Lang Technovation that machinists appreciate for tool clearance, as well as a model from Jergens that they appreciate for a secure grip). With workholding pre-configured and already mounted on the pallet and standard sizes for blanks, changing over to a new part is a simple matter of choosing the right-size collet or vise, and in the latter case, a new set of custom jaws. Generally, the only items to affix or remove from the pallets are the workpieces themselves.

What the Experts Say



Jeff Thurn
GM, Operations Manager
Metalcraft Inc.

Metal Craft is a second generation family owned manufacturer of medical instruments. As medical parts get smaller their tolerances get tighter. We looked for a precision 5-axis machining center combined with its own automation system. After visiting the Jingdiao headquarters, we decided to purchase their GRA200 combined with their 24-station pallet changer. Their engineers were at Metalcraft when our machined arrived and started the installation after the machine was in place. I was really impressed when they verified the machine which included laser calibration, ball bar and axis straightness and the results were even better than the factory specifications. After Jingdiao completed our on-site machine, automation and Surfmill CAM training, they assisted us in running some parts. Our team of machinists use the on-machine measurement software and automatic alignment system which reduces set up time. Jingdiao's support was very responsive, and they made follow up visits to ensure our satisfaction. It been a good experience working with Jingdiao North America and their local dealer Jeff Johnson of Alltech Machinery



Jeff Johnson
Owner
Alltech Machinery Sales

All Tech Machinery has represented the very best machine tool manufactures in the world. We see an incredible value in high quality machinery, automation and in-process inspection solutions. In the global manufacturing market, we seldom see technology that is this disruptive to an industry. All disciplines of the machining process are under JINGDIAO's control. No other machine tool corporations can claim this. In addition there are only a couple of machine tool builders capable of successfully making these close tolerance high quality parts.



Paul Peltier
President
Preferred Tool

Preferred Tool is a second generation family-owned and -operated custom mold manufacturer located in Hugo, MN. We purchased a JINGDIAO GRA200-GRAPHITE 5 axis machining center with their own 110 station electrode changer. This was going to be our first 5 axis machining had many advantages like reduced setups, longer tool life, and combined with our own automation system reduces electrode machining production costs. There was a team of JINGDIAO engineers that installed both the machine and the automation system. They also lasered verified the machine, provided on-site training, and assisted operators as they cut their first electrodes. JINGDIAO also worked with our 3rd party CAM provider in order to get the post processor written. The machine has made us more productive and we are very pleased with the Jingdiao machine and support.



Brian Stall
3D Application Engineer
Gosiger

As the Gosiger 3D Application Engineer, I spent over 500 machining hours during an 8-week period evaluating the JINGDIAO 5-axis mill at our Dayton headquarters. The JINGDIAO engineers supported me during the entire process. If they couldn't answer a question, they would have it the next day. I was extremely impressed with their technical skills and response time. I cut multiple samples on the JINGDIAO GRA400 5-axis machining center including micron-level parts with finishes down to a 2RMS. Parts were programmed both with 3rd party CAM software and JINGDIAO's own Surfmill CAM software. I found Surfmill to be intuitive, and powerful with many standard features. Because of the machine's rigid bridge style construction, thermal stability, 3D tool compensation and on-machine measurement, the JINGDIAO can cut high precision parts. It is one of the most precise machines that I have ever seen and we now represent JINGDIAO exclusively in all of our territories.

Dealer Network

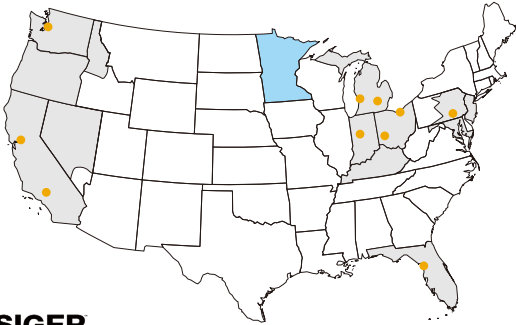

GOSIGER
SERIOUS SOLUTIONS

Dayton Distribution Center

Ohio
108 McDonough St.
Dayton, OH 45402
937-228-5189

Cleveland Distribution Center

Ohio
30600 Solon Industrial Pkwy
Solon, OH 44139
440-248-3111

Indiana Distribution Center

Indiana
4627 Independence Square
Indianapolis, IN 46203
371-788-1501

Southeast Distribution Center

Florida
2717 Rew Circle.
Ocoee, FL 34761
407-656-1411

Mid-Atlantic Distribution Center

Pennsylvania
322 Commerce Dr.
Exton, PA 19341
610-524-7722

Washington Distribution Center

Washington
21911 68th Ave South
Kent, WA 98032
253-826-3921

Michigan Distribution Center

Michigan
14600 Keel St.
Plymouth, MI 48170
734-582-2100

Grand Rapids Tech Center

Michigan
5920 Crossroads Commerce
Pkwy SW Suite A
Wyoming, MI 49519
734-582-2100



Minnesota

Alltech Machinery
10650 Country Rd 81
Maple grove, MN 55369
763-370-4670

California Distribution Center

California
6400 Gateway Dr
Cypress, CA 90630
714-446-7770

California Distribution Center

California
2033 Gateway Place, Suite 500
San Jose, CA 95110
669-234-3891

JINGDIAO NORTH AMERICA, INC.

1400 E. Business Center Drive, Ste. 103,
Mount Prospect, IL 60056
Email: usa@jingdiao.com



Lets get social:

